

# SHOP MAINTENANCE

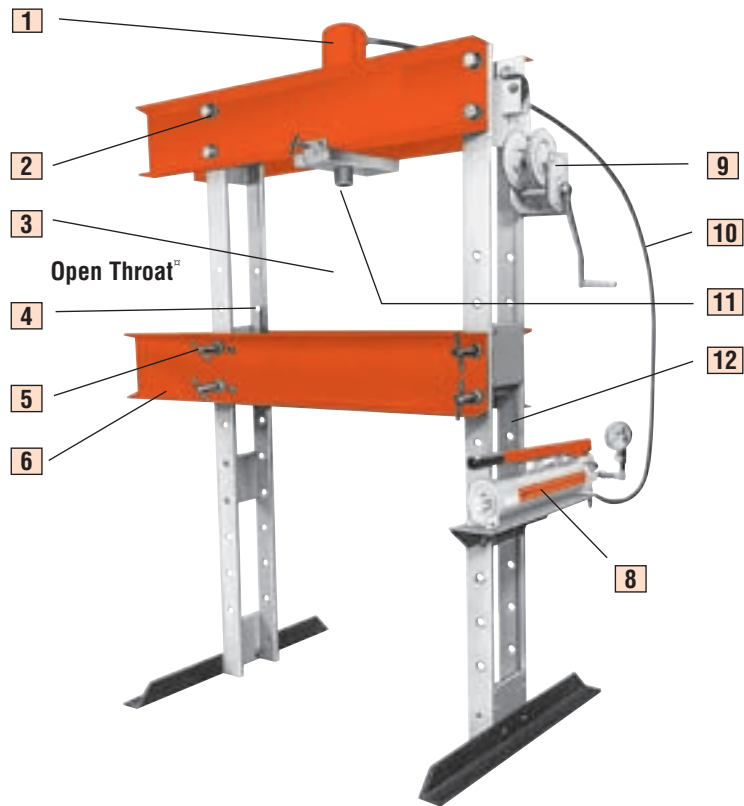

THE UNIQUE BENEFITS OF THE POWER TEAM PRESS

## ALL SHOP PRESSES AVAILABLE IN CE

**1 2 TO 1 SAFETY FACTOR** on hydraulic cylinders and they meet ASME B30.1 standards. Cylinders are easily removed for other applications. Single- or double-acting cylinders are available; built-in relief valve on double-acting cylinders.

**2 FULL RATED CAPACITY** across width of upper frame, even with workhead moved to one side. (Heavy-duty presses only.)

**3 LARGER WORK AREA** than most competitors' models.

**4 ALIGNMENT LEVER** for simple pin replacement after raising or lowering the bed.

**5 CLOSE MANUFACTURING TOLERANCE** allows even load distribution over four alloy steel pins; not two, like some competitors. (Heavy-duty presses only.)

**6 OPEN THROAT® FEATURE** on 25 ton press provides additional work area by

mounting cylinder on outside for C-frame advantage.

**7 FRAMES CAN BE USED HORIZONTALLY** for pressing jobs on extra-long shafts (see photo on next page).

**8 ELECTRIC, AIR OR HAND HYDRAULIC PUMPS** are available. All are standard Power Team pumps.

**CE approved electric pumps are standard on all presses. Externally adjustable relief valve** for precise operator

control of working pressure is standard on all electric pumps except PE10 and PE17 series.

**24 volt hand switch** for remote control on pumps equipped with solenoid valves.

**9 ONE-MAN OPERATION** for bed adjustment. Winch unit quickly raises or lowers bed to desired height. Self-locking winch mechanism prevents bed from dropping when handle is released.

### Horizontal pressing capabilities

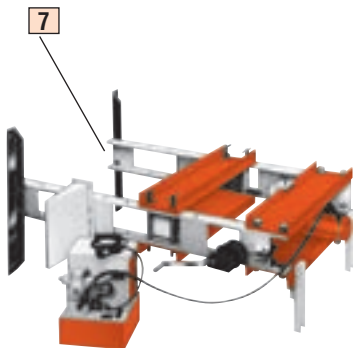

**10** 9,5 MM I.D. HOSE on spring return cylinders on heavy-duty presses provides up to six times faster cylinder return than standard 6,4 mm I.D. hose.

**11** FAST CYLINDER APPROACH to work provided by 2-speed hand, air or electric pumps.

**12** RUGGED UPRIGHTS, 50 percent stronger than channel iron. Four post design means open side for easy loading of long material.

**NOTE:** Certain features do not apply to Power Team 10 ton, Roll-Bed, or economy presses.

**NOTE:** Certain press applications may require guarding. Because of the multitude of possible press uses, it is impossible to design a guard that will meet every customer need. The end user must provide their own guarding where the situations dictate.

#### IMPORTANT SAFETY INFORMATION:

Power Team has protective blankets available which may afford protection from injury to users and others should part breakage occur. Power Team recommends the use of these blankets for all pushing, pulling, pressing, and lifting applications. See page 217 for additional information.

Page  
**C FRAME...136**



Page  
**H FRAME...137**  
**25-55 TON**



Page  
**H FRAME...140**  
**100-200 TON**



Page  
**H FRAME ...142**  
**80-200 TON**  
**ROLL BED**



Page  
**ACCESSORIES...144**



Page  
**...146**  
**FLOOR CRANES**



Page  
**...147**  
**LOADROTORS®**



# Shop Press

## C FRAME

25 Tons  
Press

SHOP EQUIPMENT

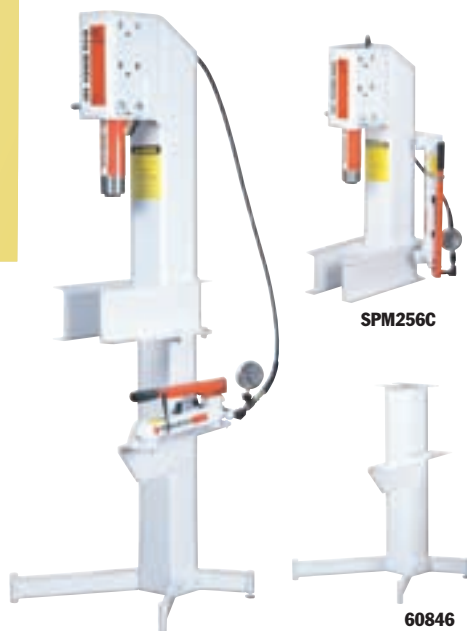

- Can be bench mounted or on optional pedestal base.
- Bench mount requires less than 1.4 sq. m. of space; on optional pedestal, only 4 sq.m. of floor space is needed.
- "Open Throat" design makes loading and unloading of work easy.
- Cylinder head adjusts to three convenient working positions, providing up to 514 mm of "daylight."
- Hydraulic cylinder delivers a 159 mm stroke, is driven by a P59 two-speed hand pump.
- **Pedestal Base No. 60846** – Provides a stable base for SPM256C. Includes a bracket for mounting the pump on the side of pedestal press. Wt., 34,5 kg.

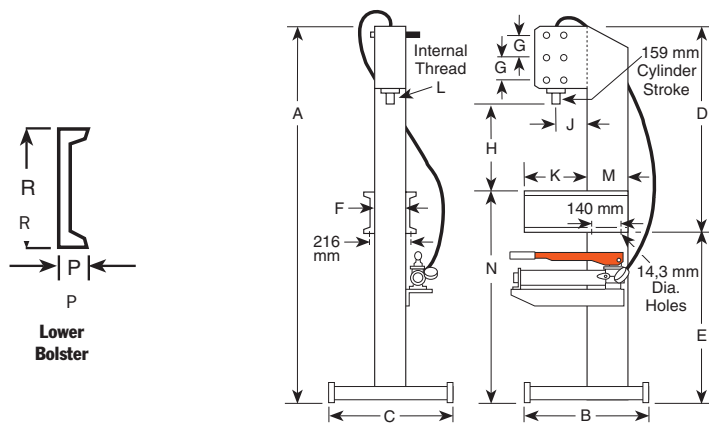

### DIMENSIONS

A	B	C	D	E	F	G	H (Cyl. Retracted)	J	K	L	M	N	P	R	Floor Space
(mm)	(mm)	(mm)	(mm)	(mm)	(mm)	(mm)	(mm)	(mm)	(mm)	(mm)	(mm)	(mm)	(mm)	(mm)	(mm)
1.972	622	610	1.057	914	152	127	260, 387, 514	165	318	1½ - 16	203	1.092	51	178	610 x 622

CE

### ORDERING INFORMATION

Capacity (tons)	Type Cyl. Used	Stroke (mm)	Cyl. Model	Order No.	Speed** Advance	Pressing	Type Pump	Pump Model	Prod.Wt. (kg)
25	Single-Acting	159	C256C	SPM256C*	3,3 mm/ stroke	0,8 mm/ stroke	Hand	P59	108

\* SPM256C does not include No. 60846 pedestal base.

\*\* Typical performance based on pump specifications. Actual speeds may vary with operating conditions.

# Shop Press H FRAME

## 10 Tons Bench/Floor Press

- Ideal for small pressing jobs; repairing small motors, armatures, removing and installing gears, bearings, other press-fit parts.
- Bench press has 391 x 457 mm work area; floor press bed height is adjustable from 127 mm to 1.041 mm with horizontal "daylight" of 553 mm.
- Choices of power sources: single-speed hand pump, electric/hydraulic or air/hydraulic.
- Hydraulic gauges, hoses and fittings included.

### PUMP ELECTRICAL SPECIFICATIONS

PE10 Series – 220 volt, 50 cycle, single phase.

# CE



SP1010A



SPM1010

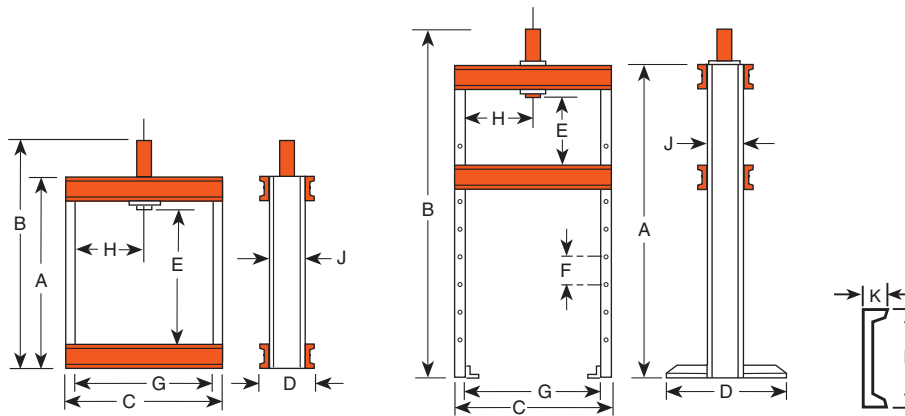

### DIMENSIONS

	A	B	C	D	E	F	G	H	J	K	L	Bench Space	Floor Space
Frame	(mm)	(mm)	(mm)	(mm)	(mm)	(mm)	(mm)	(mm)	(mm)	(mm)	(mm)	(mm)	(mm)
<b>Bench</b>	622	841	641	182	391	—	559	279	102	40	102	182 x 641	—
<b>Floor</b>	1.499	1.718	641	711	127-1.041	152	559	63,5-470*	102	40	102	—	711 x 730

\*Lateral head movement

### ORDERING INFORMATION

Frame	Cap. (tons)	Type of Cyl. Used	Stroke	Cylinder Model	Order No.	Speed (mm./min.)†††	Type Pump	Pump Model †	Prod. Wt. (kg)
222481 Bench	10	Single-Acting	257	C1010C	<b>SPM1010</b>	1,5 mm/stroke	Hand	P55	41,2
222480 Floor	10	Single-Acting	257	C1010C	<b>SPH1010</b>	1,5 mm/stroke	Hand	P55	77,5
222480 Floor	10	Single-Acting	257	C1010C	<b>SPE1010</b>	55,7 5,1	Elec. ††	PE172-E220	79,3
222480 Floor	10	Single-Acting	257	C1010C	<b>SP1010A</b>	93,7 7,6	Air	PA9H	78,1
222480 Floor	10	Double-Acting	254	RD1010	<b>SPE1010D</b>	55,7 5,1	Elec. ††	PE174-E220	87,0

† Optional air/hydraulic pumps available on request.

†† "Advance" position holds pressure with motor shut off. "Return" position advances cylinder with motor running and returns cylinder with motor shut off.

††† Typical performance based on 7 bar and 700 bar pump specifications. Actual speeds may vary with operating conditions.

PRESS ACCESSORIES

Page 144-145

# Press H FRAME

## Open Throat & Economy Press 25 Ton

Presses

SHOP EQUIPMENT

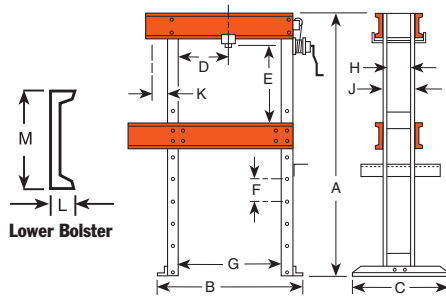

### OPEN THROAT PRESSES

- Design permits use as both "H" frame and "C" frame press; cylinder can be mounted on frame extension to handle jobs which won't fit between uprights.
- Open throat press models are also available with remote control to enable the operator to view work from all sides with fingertip control of cylinder piston travel.
- Off-center pressing loads of full capacity can be applied across entire width of frame.

### ECONOMY PRESSES

- Rugged, yet reasonably priced. Handles many "big press" tasks, and perfect for many of the "in-between" jobs you see almost daily. (Note: stroke length limited to 159 mm on economy models.)

### FEATURES OF BOTH OPEN THROAT AND ECONOMY PRESSES

- Press bed height easily adjustable with winch. Bed will not drop when handle is released.
- Choice of power sources for rapid cylinder advance: two-speed hydraulic hand pump, electric/hydraulic or air/hydraulic.

### PUMP ELECTRICAL SPECIFICATIONS

**PE17 Series** – 0,37 KW, 220 volt, 50 cycle, single phase.

CE

### DIMENSIONS

A (mm)	B (mm)	C (mm)	D* (mm)	E (mm)	F (mm)	G (mm)	H (mm)	J (mm)	K (mm)	L (mm)	M (mm)	Floor Space (mm)
1.727	1.092	711	76-737	175-1.102	114	813	140	165	178	64	203	1.092 x 711

\*Lateral head movement

### ORDERING INFORMATION

Cap. (tons)	Type of Cylinder Used	Stroke (mm)	Cylinder Model	Order No.	Speed (mm/min.) <sup>††</sup>	Advance	Pressing	Type Pump	Valve Type	Pump <sup>‡</sup> Model	Prod.Wt. (kg)
<b>"Open Throat" presses</b>											
25	Single-Acting	362	C2514C	<b>SPA2514</b>	249	30		Air	2-Way Foot	PA6	309
25	Single-Acting	362	C2514C	<b>SPM2514</b>	12,4 mm/ stroke	0,8 mm/ stroke		Hand	Load - Release	P159	314
25	Single-Acting	362	C2514C	<b>SPE2514</b>	1.184	84		Elec.	2-Way <sup>†††</sup>	PE172-E220	301
25	Single-Acting	362	C2514C	<b>SPE2514S</b>	1.321	102		Elec.	3-Way <sup>†</sup>	PE172S-E220	344
25	Double-Acting	362	RD2514	<b>SPE2514DS</b>	1.321	102		Elec.	4-Way <sup>†</sup>	PE174S-E220	357
<b>"Economy" presses</b>											
25	Single-Acting	159	C256C	<b>SPA256</b>	249	30		Air	2-Way Foot	PA6	197
25	Single-Acting	159	C256C	<b>SPM256</b>	3,0 mm/ stroke	0,8 mm/ stroke		Hand	Load - Release	P59	205
25	Single-Acting	159	C256C	<b>SPE256</b>	1.184	84		Elec.	2-Way <sup>†††</sup>	PE172-E220	210

† Solenoid valve with 12 volt remote control hand switch.

†† Holds pressure with motor shut off. Also has an automatic dump setting. Furnished with a 3.1m remote motor control.

††† Typical performance based on 7 bar and 700 bar pump specifications. Actual speeds may vary under operating conditions.

‡ Pump standard with press. Other Power Team pumps can be substituted.

dBA at idle and 700 bar: PE172-67/81 dBA; measured at 0,9 m distance, all sides.

- Full off-center pressing at full rated capacity across width of upper frame without buckling or bending.
- Maximum "daylight" is 1067 x 914 mm, making positioning of even bulky work pieces easy.
- Height of press bed is easily adjusted with winch; friction brake prevents bed from dropping and handle from spinning upon release.
- Presses with single-acting cylinder offer choice of 2-speed hand operated, electric/hydraulic, or air/hydraulic pump. Models with double-acting cylinder have an electric/hydraulic pump.
- Press models equipped with remote control enable operator to view work from all sides with fingertip control of cylinder piston travel.
- Press can be used horizontally for special applications with user-supplied support legs.

# Press H FRAME

## 55 Ton Presses



Hydraulic gauge and hydraulic fittings are included with presses.

### PUMP ELECTRICAL SPECIFICATIONS

**PE17 Series** – 0,4 Kw, 220 volt, 50 cycle, single phase.

# CE

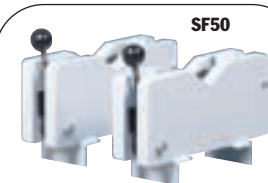
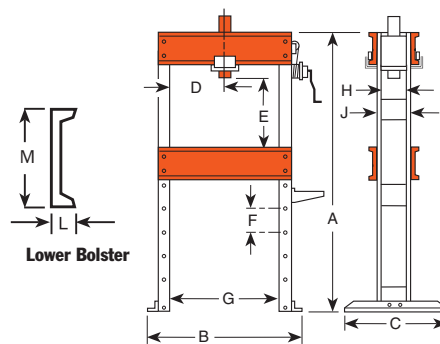

**No. SF50** – Straightening fixtures for use with 55-ton shop or 80-ton Roll-Bed® presses (2 ea.). Wt., 47,2 kg. **Not part of press, order separately.**

SHOP EQUIPMENT

### DIMENSIONS

A (mm)	B (mm)	C (mm)	D* (mm)	E (mm)	F (mm)	G (mm)	H (mm)	J (mm)	L (mm)	M (mm)	Floor Space (mm)
1.829	1.232	914	83-832	152-1.067	152	914	171	203	76	305	1.232 x 914

\*Lateral head movement

### ORDERING INFORMATION

Cap. (tons)†	Type of Cylinder Used	Stroke (mm)	Cylinder Model	Order No.	Speed (mm/min.)††	Type Pump	Valve Type	Pump‡ Model	Prod.Wt. (kg)
55	Single-Acting	159	C556C	<b>SPA556</b>	114	Air	2-Way Foot	PA6	318
55	Single-Acting	159	C556C	<b>SPM556</b>	5,8 mm/ stroke	Hand	Load- Release	P159	323
55	Single-Acting	337	C5513C	<b>SPM5513</b>	18,9 mm/ stroke	Hand	2-Way	P460	435
55	Single-Acting	159	C556C	<b>SPE556</b>	551	Elec.	2-Way††	PE172-E220	333
55	Single-Acting	337	C5513C	<b>SPE5513</b>	551	Elec.	2-Way††	PE172-E220	444
55	Single-Acting	337	C5513C	<b>SPE5513S</b>	620	Elec.	3-Way†	PE172S-E220	478
55	Double-Acting	333	RD5513	<b>SPE5513D</b>	551	Elec.	4-Way	PE174-E220	450
55	Double-Acting	333	RD5513	<b>SPE5513DS</b>	1.679	Elec.	4-Way†	PE554S-E220	505

- \* Frame is shipped assembled.
- † Solenoid valve with 24 volt remote control hand switch.
- †† Holds pressure with motor shut off. Also has an automatic dump setting. Furnished with a 3,1 m remote motor control.
- ††† Typical performance based on 7 bar and 700 bar pump specifications. Actual speeds may vary with operating conditions.
- ‡ Pump standard with press. Other Power Team pumps can be substituted. dBA at idle and 700 bar: PE172—67/81; measured at 0,9 m distance, all sides.

PRESS ACCESSORIES

Page 144-145

www.powerteam.com

139

# H Frame Presses

## 100 Ton Presses

SHOP EQUIPMENT

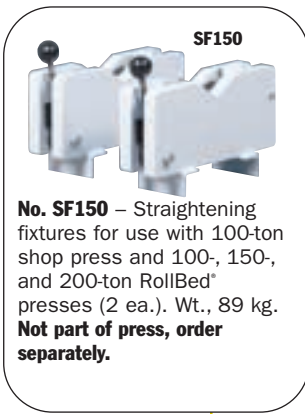

- Cylinder workhead glides across upper frame on rollers, locks in place for off-center pressing jobs. May be used horizontally for special pressing applications with user-supplied supports.
- Press bed is raised and lowered by winch which locks in place for insertion of bed retaining pins. Upper bolster can be lowered 203 mm for convenient positioning on repetitive jobs.
- Generous "daylight" of 1.067 x 1.270 mm accommodates bulky work pieces, uprights are placed for easy side entry of bars or shafts for straightening or bending.
- Choice of single- or double-acting cylinder. Hydraulic pump options include: 2-speed hand pump with large 7,6 l reservoir, PE172 electric/hydraulic pump or "PQ" series "Quiet" electric/hydraulic pump with low noise level.



### PUMP ELECTRICAL SPECIFICATIONS

**PE17 Series** – 0,4 KW, 220 volt, 50 cycle, single phase.

**PQ120 Series** – 2,2 kW, 380 V, 50 cycle, three phase.

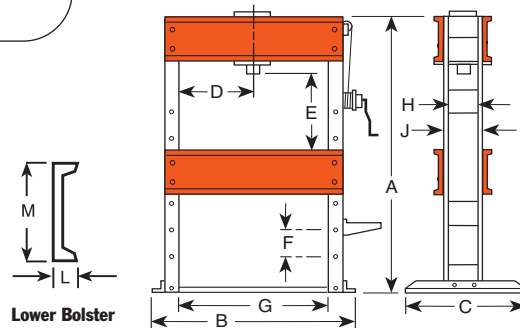

**CE**

### DIMENSIONS

A (mm)	B (mm)	C (mm)	D* (mm)	E (mm)	F (mm)	G (mm)	H (mm)	J (mm)	L (mm)	M (mm)	Floor Space (mm)
1.962	1.626	914	178-1.092	51-1.067	203	1.270	203	254	86	381	914 x 1.988

\*Lateral head movement

### ORDERING INFORMATION

Cap. (tons)†	Type of Cyl. Used	Stroke (mm)	Cylinder Model	Order No.	Speed (mm/min.)†† Advance	Pressing stroke	Type Pump	Valve Type	Pump‡ Model	Prod. Wt. (kg)
100	Single-Acting	260	C10010C	<b>SPM10010</b>	9,0 mm/ stroke	0,3 mm/ stroke	Hand	3-way	P460	769
100	Single-Acting	260	C10010C	<b>SPE10010</b>	889	74	Elec.	3-way	PE552-E220	813
100	Single-Acting	260	C10010C	<b>SPE10010R</b>	292	20	Elec.	2-way	PE172-E220	766
100	Double-Acting	333	RD10013	<b>SPE10013DS</b>	889	147	Elec.	4-way*	PQ1204SE380	854

† Frame is shipped assembled. \*Solenoid valve with 24 volt remote control hand switch.

†† Typical performance based on 7 bar and 700 bar pump specifications. Actual speeds may vary under operating conditions.

‡ Pump standard with press. Other Power Team pumps can be substituted.

dBA at idle and 700 bar: PE172—67/81; PQ120—73/78. Measured at 0,9 m distance, all sides.

- Standing 2,3 m tall, these giants handle the really big jobs. May be used horizontally for special pressing applications with user-supplied supports.
- Workhead has wide horizontal travel; rugged press frame withstands load of rated capacity across full width of frame.
- Winch mechanism provides easy positioning of press bed, locks in place for insertion of retaining pins. Upper bolster can be lowered 279 mm for convenient positioning on repetitive jobs.
- Uprights are placed for easy side entry of bars or shafts for straightening or bending.
- Fast cylinder approach is provided by PQ1204S "Quiet" electric/hydraulic pump. Has remote control hand switch, enabling operator to view work from all sides with fingertip control of cylinder piston travel.

### PUMP ELECTRICAL SPECIFICATIONS

**PQ120 Series** – 2,24 KW, 380 volt, 50 cycle, three phase.



Hydraulic gauge and hydraulic fittings are included with presses.

# H Frame Presses

150-200 Ton Presses

CE

SHOP EQUIPMENT

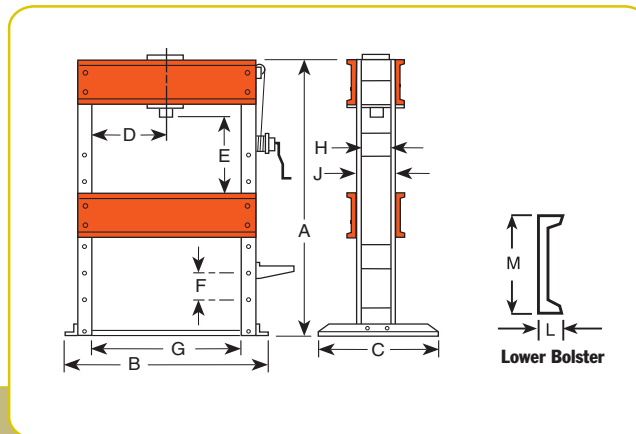

### DIMENSIONS

A (mm)	B (mm)	C (mm)	D* (mm)	E (mm)	F (mm)	G (mm)	H (mm)	J (mm)	L (mm)	M (mm)	Floor Space (mm)
2.286	1.803	1,118	279-991	228-1.111	279	1.270	318	381	105	457	1.117 x 1.803

\*Lateral head movement

### ORDERING INFORMATION

Capacity (tons)†	Type of Cylinder Used	Stroke (mm)	Cylinder Model	Order No.	Speed (mm/min.)†† Advance	Pressing	Type Pump	Valve Type	Pump Model***	Prod. Wt. (kg)
150	Double-Acting	333	RD15013	<b>SPE15013DS</b>	610	99	Electric	4-way**	PQ1204S-E380	1.366
200	Double-Acting	333	RD20013	<b>SPE20013DS</b>	457	74	Electric	4-way**	PQ1204S-E380	1.484

† Frame is shipped assembled.

†† Typical performance based on 7 bar and 700 bar pump specifications. Actual speeds may vary under operating conditions.

\*\* Solenoid valve with 24 volt remote control hand switch.

\*\*\* Pump standard with press. Other Power Team pumps can be substituted. dBA at idle and 700 bar: 73/78, measured at 0,9 m foot distance, all sides.

PRESS ACCESSORIES

Page 144-145

# Roll-Bed<sup>®</sup> Press

80-200 Ton  
H Frame

CE



SHOP EQUIPMENT

## Heavy-Duty Straightening Fixtures



**No. SF50** – Fixtures for use with 80-ton Roll-Bed<sup>®</sup> presses or 55-ton heavy-duty shop presses. (2 ea.). Wt. 47,2 kg. **Not part of press, order separately.**



**No. SF150** – Fixtures for use with 100-, 150- and 200-ton Roll-Bed<sup>®</sup> presses and 100-ton shop presses only (1 pr.). Wt. 89 kg. **Not part of press, order separately.**

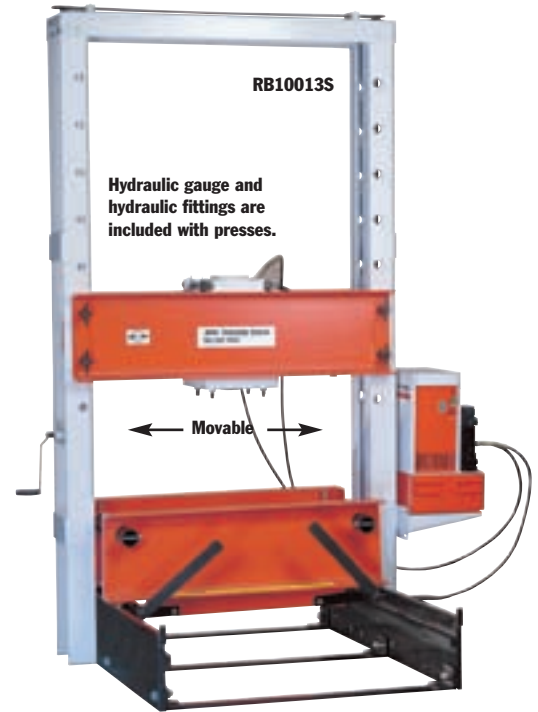

RB10013S

Hydraulic gauge and hydraulic fittings are included with presses.

Movable

- The original, patented Roll-Bed<sup>®</sup> design. Bed rolls out for easy loading and unloading with a crane or other lifting device.
- Movable workhead glides easily side-to-side for full off-center load capacity across width of upper frame.
- "Daylight" is 1.283 x 1.524 mm for 80- and 100-ton models; 1.302 x 1.625 mm on 150- and 200-ton presses.
- Fast approach of double-acting, 334 mm stroke cylinder is provided by PQ1204S "Quiet" electric/ hydraulic pump with remote control hand switch. Operator can view work from all sides with fingertip control of cylinder piston travel.

## PRESS FEATURES:

- **Roll-Bed<sup>®</sup> design** – Bed glides in or out on bearings to make loading and unloading fast and easy.
- **Adjustable lower bed width** – For secure balancing and centering of heavy jobs. Loosen adjusting bolts to adjust bed from 102 to more than 686 mm. See dimension "H."
- **Movable workhead** – For off-center pressing jobs, workhead moves on bearings across upper bolster. Presses can be used at full capacity, regardless of where workhead is placed.
- **Lifting mechanism** – Simply turn crank handle to raise or lower upper bolster. Screw mechanism raises or lowers both sides evenly (a heavy-duty 1/2" drill motor can replace handle for automatic adjustment). Four locking pins hold bolster in place for pressing.

## • Optional heavy-duty straightening fixtures

- Make straightening jobs easy and accurate to within 0.1 mm! Rollers are ball bearing mounted and handle raises or lowers for easy turning of the work.

## PUMP ELECTRICAL SPECIFICATIONS

**PQ120 Series** – 2,24 KW, 380 volt, 50 cycle, three phase.

**NOTE:** Different voltage and valve options can be obtained by substituting certain PA, PE or PQ series pumps. Consult the factory.



Lifting screw and locking pins make bolster raising a one-man job.



Bearings make bed positioning smooth and easy.



Lever lowers bed for pressing, raises it for rolling.

**CE**



Cylinder is easily moved across width of upper bolster.



Width adjusts from 102 mm to over 686 mm; is secured with locking bolts.

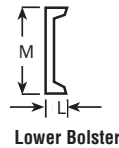
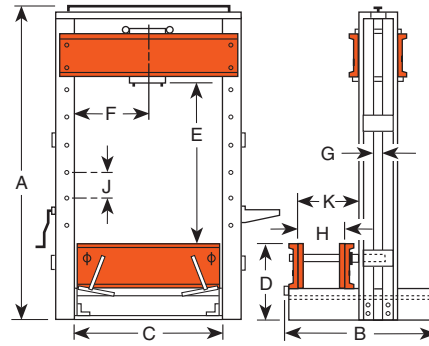

SHOP EQUIPMENT

**DIMENSIONS**

Cap (Tons)	A (mm)	B (mm)	C (mm)	D (mm)	E (mm)	F (mm)	G (mm)	H (mm)	J (mm)	K (mm)	L (mm)	M (mm)	Floor Space (mm)
80	2.861	1.632	1.283	686	305-1.524	368-914	76,2	102-692	203	927	86	381	1.632-1.537
100	2.861	1.632	1.283	686	305-1.524	368-914	76,2	102-692	203	927	86	381	1.632-1.537
150	3.131	1.734	1.302	762	229-1.626	352-949	76,2	102-689	279	946	105	457	1.734-1.607
200	3.131	1.734	1.302	762	229-1.626	352-949	76,2	102-689	279	946	105	457	1.734-1.607

**ORDERING INFORMATION**

Capacity (tons)†	Type of Cylinder Used	Stroke (mm)	Cylinder Model	Order No.	Speed (mm/min.)††	Advance	Pressing	Type Pump	Valve Type	Pump‡ Model	Prod. Wt. (kg)
80	Double Acting	333	RD8013	<b>RB8013S</b>	1.168	190		Elec.	4-way*	PQ1204S-E380	1.307
100	Double Acting	333	RD10013	<b>RB10013S</b>	889	147		Elec.	4-way*	PQ1204S-E380	1.334
150	Double Acting	333	RD15013	<b>RB15013S</b>	610	99		Elec.	4-way*	PQ1204S-E380	2.019
200	Double Acting	333	RD20013	<b>RB20013S</b>	457	74		Elec.	4-way*	PQ1204S-E380	2.059

\* Solenoid valve with 24 volt remote control hand switch.

† Frame is shipped assembled.

‡ Pump standard with press. Other Power Team pumps can be substituted. dBA at idle and 700 bar: PQ120-73/78; measured at 0,9 m distance, all sides.

†† Typical performance based on 7 bar and 700 bar pump specifications. Actual speeds may vary with operating conditions.

# Shop Press ACCESSORIES

SHOP EQUIPMENT

## Rubber Tire Removing/Installing set

Now an easy way to press solid rubber tires. The TPP200 uses plates instead of combination rings to press a rim from an old tire into a new one. Plates are stacked so none is more than 50,8 mm smaller than the one under it to keep the plates from bending. They can be used on any Power Team press with 55-ton capacity or more. NOTE: Many tires require 100 tons of force or more, depending on tire size and condition. These plates withstand max. force of 150 tons.

**No. TPP200** – Tire press plate set. Includes 13 press plates, spacer pushing adapter and press bed plate. For use on solid rubber tires from 102 mm to 451 mm I.D.

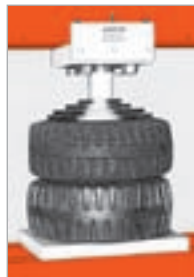
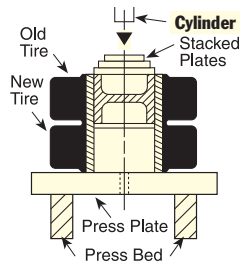

Pressing rim into new tire on Power Team Press.

Set No. TPP200

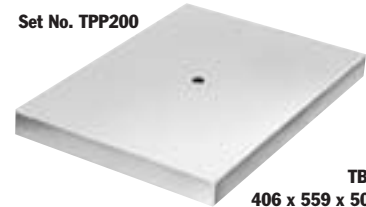

**TBP1622**  
406 x 559 x 50,8 mm



**TPP1 – TPP13**  
98,4 x 448 x 19,1 mm



**TPS6**  
95,3 x 152,4 mm

Order No.	Set No. TPP200 Tire Size I.D. (mm)	Plate O.D. (mm)
<b>TPP1</b>	102	98,4
<b>TPP2</b>	127	123,8
<b>TPP3</b>	152,159	149,2
<b>TPP4</b>	165	161,9
<b>TPP5</b>	203	200
<b>TPP6</b>	254	250,8
<b>TPP7</b>	267	263,5
<b>TPP8</b>	286	282,6
<b>TPP9</b>	305,308	301,6
<b>TPP10</b>	356	352,4
<b>TPP11</b>	381	377,8
<b>TPP12</b>	406	403,2
<b>TPP13</b>	451	447,7
<b>TPS6</b>	Spacer/Pushing Adapter	82,6 x 152,4
<b>TBP1622</b>	Bed Plate	406 x 559 x 51

## PRESS ACCESSORIES, "V" BLOCKS & THREADED ADAPTERS

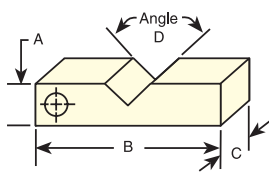

### V-BLOCKS (mm)

Order No.	Width A (mm)	Length B (mm)	Thick C (mm)	Angle D
<b>1890</b>	50,8	228,6	31,8	120°
<b>1891</b>	63,5	292,1	44,5	120°
<b>1892</b>	88,9	355,6	50,8	120°
<b>1893</b>	127	355,6	38,1	120°
<b>207395</b>	146,1	584,2	63,5	120°

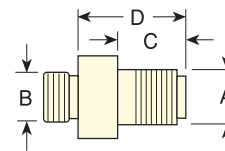

### THREADED ADAPTER DIMENSIONS

Adapter No.	A	B	C (mm)	D (mm)
38597	1-8	1-8	19,1	33,3
38953	1 1/4 - 7	1 1/2 - 16	69,9	111,1
37368	1 5/8 - 5 1/2	—	42,9	63,5
43562	2 1/4 - 12	—	57,2	76,2
38954	1 5/8 - 5 1/2	1 1/2 - 8	82,6	106,4
43563	2 1/4 - 12	2 3/4 - 12	57,2	81
46070	2 1/4 - 12	2 - 4 1/2	57,2	81

# Shop Press ACCESSORIES

## Press Accessory Kit

Make your Power Team press even more versatile with one of these accessory sets. These sets will eliminate makeshift set-ups. Many of these items can be used with pullers you already have.

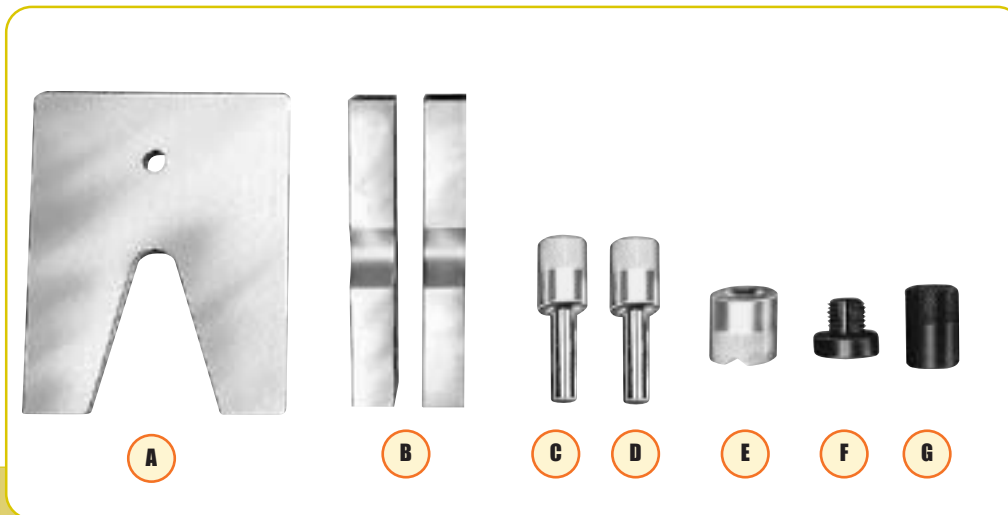

SHOP EQUIPMENT

### ORDERING INFORMATION

Use With Press:	Order No.	A	B	C	D	E	F		G
		V-Throat Press Plate	V-Blocks	Pushing Adapter ⚠	Pushing Adapter ⚠	V-Pushing Adapter	Single-Acting Cyls.	Double-Acting Cyls.	Pushing Adapter
10 Ton	<b>SPA10</b>	1888	1890 (Pr.)	<b>201923</b> 12,7 mm dia. shank	<b>201454</b> 19 mm dia. shank	34806	Included in Set 38597	— 38597	—
25 Ton	<b>SPA25</b>	1889	1891 (Pr.)	<b>34510</b> 19 mm dia. shank	<b>34511</b> 25,4 mm dia. shank	34807	Included in Set 38953	— 38953	—
55 Ton	<b>SPA55</b>	—	1892 (Pr.)	<b>34755</b> 25,4 mm dia. shank	<b>34756</b> 31,8 mm dia. shank	34808	Not Included Order Separately 37368	— 38954	—
80/100 Ton	<b>SPA100</b>	—	1893 ** (Pr.)	—	—	36469 43562	Not Included Order Separately 43562 46070 ***	— 43563 46070	21332
150/200 Ton	<b>SPA200</b>	—	207395 (Pr.)	—	<b>44458</b> 57,1 mm dia. shank	44457	None*	—	—

\* Pushing adapters thread directly into RD15013 and RD20013 cylinders.

\*\* V-blocks, No. 1893, are recommended for use with 80-ton Roll-Bed® press. Not recommended for use with 100-ton Roll-Bed®.

\*\*\* For 80-ton Roll-Bed® press.

NOTE: Individual press accessories may be ordered separately.



**CAUTION:** Pushing adapters are designed for use with specific shaft sizes, and depending on the condition of the shaft ends, the adapter may not withstand the full press tonnage. Always use a protective blanket or other suitable guard when pressing.

# Mobile Floor Cranes

1000- 2000 kg

SHOP EQUIPMENT

1000 kg and 2000 kg capacity with space-saving fold-away feature



- Adjustable legs spread to clear obstacles, telescoping boom for extra reach. Rugged construction, reliable hydraulics.
- Boom collapses completely and legs fold for compact storage.
- 2-speed hydraulic hand pump provides fast boom travel and precise operator controlled descent.
- Roller bearing wheels and a steering dolly provide ease of mobility. Lifting chain is included.

**No. FC4400** – 2000 kg cap. crane with fold-away feature, adj. leg spread, lifting chain and 2-speed hand pump. Wt. 293 kg.

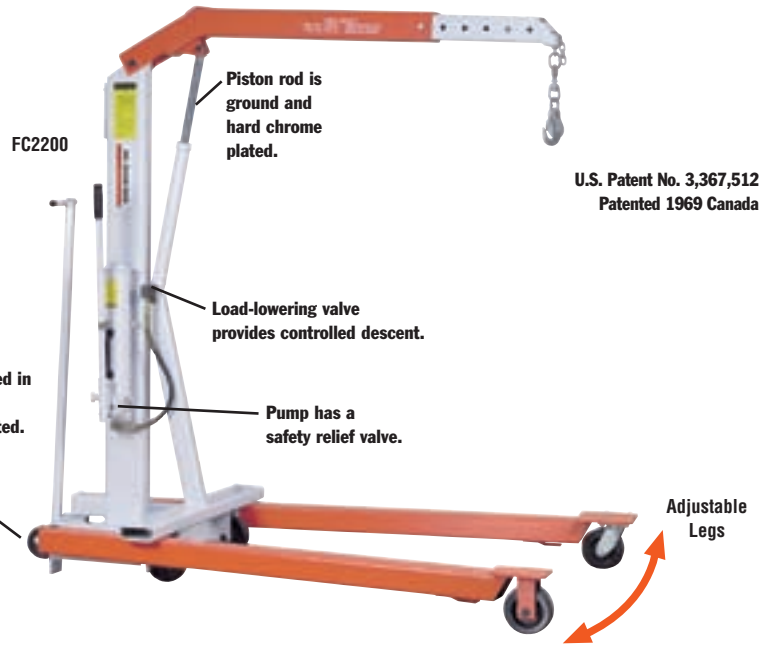

U.S. Patent No. 3,367,512  
Patented 1969 Canada

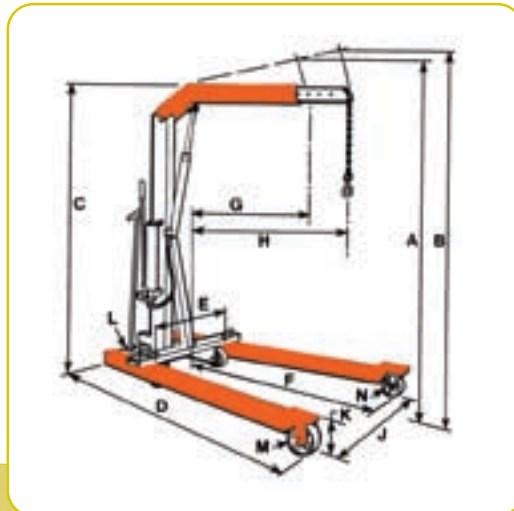

## DIMENSIONS

	FC2200*	FC4400*
Cap., boom ret. (kg)	1.000	2.000
Cap., boom ext. (kg)	750	1.500
A Max. boom hgt., ret (mm)	2,718	2.819
B Max. boom hgt., ext.(mm)	2.972	3.099
C Overall hgt., boom horiz.(mm)	2.032	2.083
D Overall length (mm)	2.108	2.261
E Min. throat width (mm)	610	635
F Inside leg length (mm)	1.372	1.461
G Eff. boom reach -ret.(mm)	838	902
H Eff. boom reach -ext. (mm)	1.219	1.238
J Inside leg width (mm)	610-914-1.219	660-1.016-1.333
	<b>(3 -position)</b>	<b>(3 -position)</b>
K Leg height (mm)	203	241
L Dolly wheel diameter(mm)	127	127
M Wheel diameter (mm)	152	203
N Caster diameter (mm)	152	152
space, folded (mm)	686 x 965	787 x 1.067
Height, folded (mm)	2.007	2.184

\* Frame shipped unassembled.

Load-Rotors®

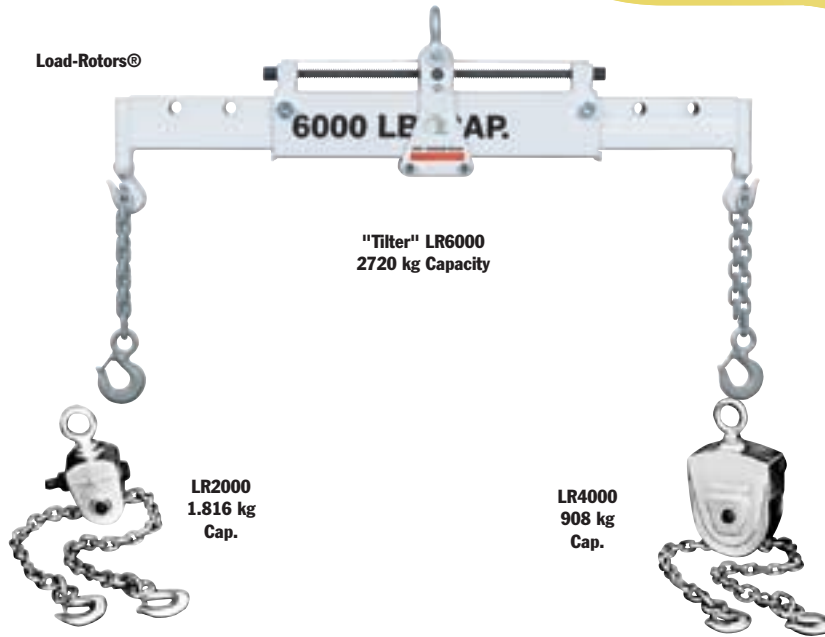

"Tilter" LR6000  
2720 kg Capacity

LR2000  
1.816 kg  
Cap.

LR4000  
908 kg  
Cap.

# Load-Rotors<sup>®</sup> TILTERS

908-2720 kg

SHOP EQUIPMENT

- For lifting or positioning components, Power Team's heavy duty lifting slings are just right.
- The heavy-duty Load-Rotors®, when used with a crane or hoist, greatly reduce time and effort.
- A self-locking worm and gear set in the Load-Rotor® head permits rapid angle adjustment of the component being handled.
- Whenever you have big, heavy components to move or position, nothing helps you get the job done easier and faster than the 2.720 kg "Tilter."

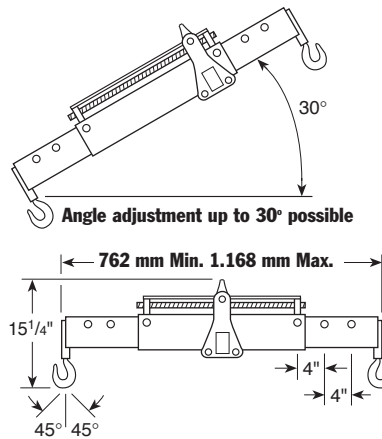

The working length is adjustable in three positions from 762 mm to 1.168 mm. Maximum chain angle is 45°.

### ORDERING INFORMATION

Capacity (kg)	Order No.	Chain Size (mm)	Chain Lg. W/ Swivel Hooks (mm)	Lifting Eye Opening (mm)	Hex Drive End (in)	Gear Ratio	Product Wt. (kg)
2000	LR2000	6,4	1.422	31,8	5/8	34:1	4,1
4000	LR4000	7,9	1.650	44,5	5/8	82:1	10,4
6000	LR6000	7,9	1.650	41,3	5/8	82:1	33,1